

D SERIES 4 WHEEL T-3 TOTE



Most Versatile Tote!

The T-3 Tote is the most versatile tote we make. With its 30 gallon tank, this tote makes filtering, transferring, and topping off reservoirs a breeze. It can fill itself, be used as an off-line filter for cleaning different reservoirs, and to pump oil into various containers. This tote has all the power needed for filtering oil viscosities up to 600cSt (ISO VG 680) at 100°F within ambient temperature ranges of -15°F to 150°F.

Typical Applications:

- Filtering contaminated systems
- Flushing new or repaired systems
- Pre-filtering new oil
- Transferring oils
- Topping off reservoirs or containers
- Dispensing new oil

ForFluids.com

D SERIES 4 WHEEL T-3 TOTE

Don't see the options you need?
Contact For Fluids at 1(630) 922-5020
for more information.

Performance:

For filtering mineral and synthetic based oils (hydraulic oils, gear oils and turbine oils) with a maximum operating viscosity range of ISO VG 680 (3000ssu/648cSt) at 100 °F within ambient temperature ranges of -15 °F to 150 °F.

Standard Features:

Frame:	Carbon steel, 30 gallon tank with 4 wheels
Paint:	Multiple color options available
Motor:	1HP, 115vac, 60Hz or Pneumatic
Filter Heads:	Medium pressure, cast aluminum heads
Pump:	Heavy duty, cast steel gear pump. Available in 1, 2, 5 and 10 GPM
Connections:	Various quick connect options available
Hoses:	7ft. Clear PVC, steel reinforced hose or hydraulic hose
Power Switch:	Sealed on/off power switch
Cord Reel:	40ft. retractable electric cord reel
Breather:	Desiccant Breather
Filter Indicators:	Slide bar indicators trigger at 50psid when elements need to be changed
Pump Relief:	Opens at 150psi
Weight:	Approx. 125lbs (will vary depending on options)
Dimensions:	Approx. 30"L x 19"W x 35"H

Replacement Elements:

Part Number	BETA Rating	Desired Cleanliness Level (ISO Code)
P1066	β4(c)=2000	14/12/9 - 13/11/8
P1065	β7(c)=2000	18/16/13 - 15/13/10
P1063	β10(c)=1000	19/17/14 - 18/16/13
P1064	β25(c)=2000	20/18/15 - 19/17/14
P1048WR	Water Removal	

All D Series elements measure 5" x 14".

Components:

Item Number	Description	Qty.
1	Tank	1
2	Motor	1
3	Pump	1
4	Filter Head	2
5	Filter Element	2
6	Filter Indicator	2
7	Switch On/Off	1
8	Sample Port	2
9	Cord Reel	1
10	Sight Gauge	1
11	Breather Adapter	1
12	Breather	1
13	Brake	2

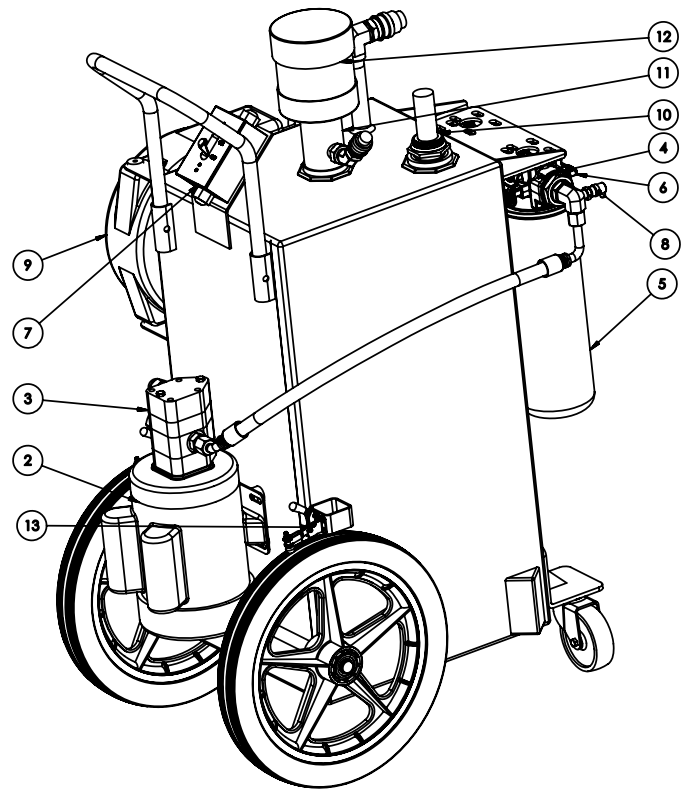

ForFluids.com

5365 Walnut Ave Downers Grove, IL 60515 | 630-922-5020 | ForFluids.com